

KLARO

KLARO grease separator KL *sepa.pop*

We provide clear water

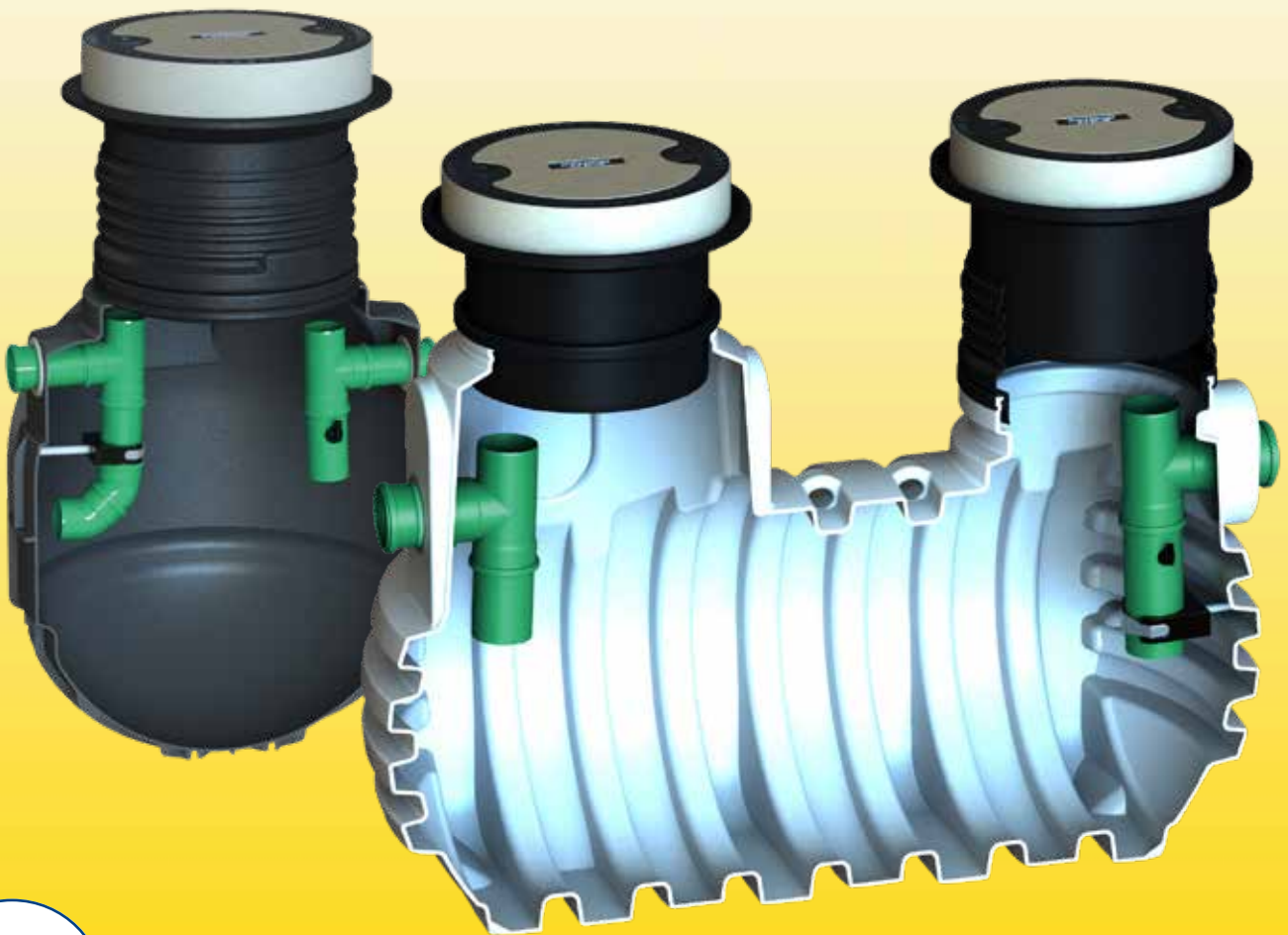

2018

Item no. 107-EN-0318

KLARO separator technology

Grease separator **KL** *sepa.pop*

KLsepa.pop NS 1-4 *Saphir*



KLsepa.pop NS 4-15 *Diamant*

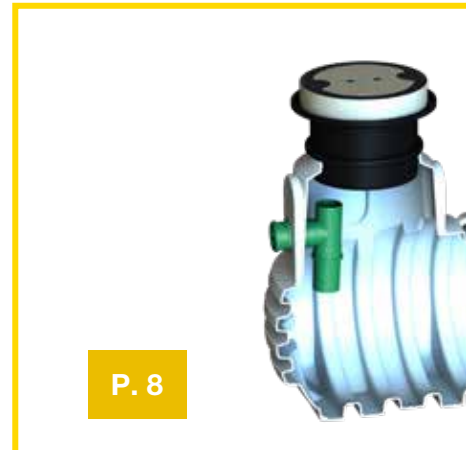

Advantages of the KLARO ...

... Grease separator

- All assembly components in plastic
- Compact grease separator optimised in terms of volume
- Up to nominal size (NS) 15 (= nominal flow rate 15 l/s)
- Compact sizes
- Sturdy assembly components, which are easily accessible

... Plastic tanks

- Seamless tank, manufactured in one piece
- Low transportation costs
- Attachment parts in plastic with variable height and level adjustment
- Low maintenance costs with easy-clean internal surfaces
- No degradable inner lining



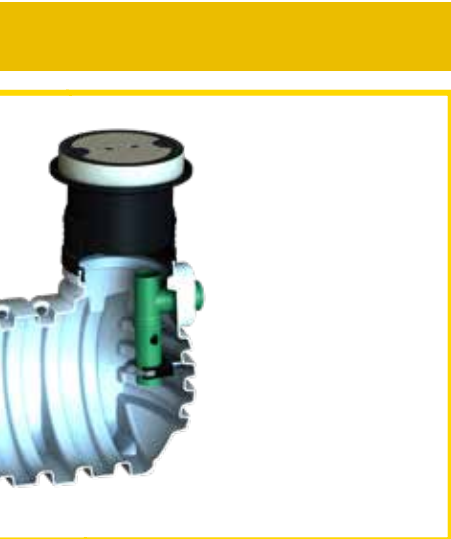

Accessories



Sampling shaft 8

Dome assembly 9

Warning systems 9



P. 7

i Information

KLARO GmbH in Bayreuth 4

Grease separator system 5

Areas of application 6

Information 10

Road map for separator 10

Distinction according to the region 10

Monitoring and drainage 10

CE Declaration of performance 11

Authorisation number 11

KLARO GmbH in Bayreuth



KLARO company in Bayreuth

KLARO GmbH, in Bayreuth, has been ensuring clear water since 2001. The staff, consisting of around 30 employees from different areas, always finds an optimised and practicable solution for your requirements. Through our experience and continuous development we have established a portfolio of high quality, clarification solutions for decentralized wastewater treatment. Worldwide there are already 500,000 people who rely on proven KLARO technology.

Further innovations are the KLARO separator systems that used to be manufactured from concrete. Nowadays, these are sold on the market as easy to handle plastic tanks with a number of benefits. We offer two sophisticated, class I and class II light fluid separators with the KLsepa.compact. The range of separators is complemented by the KLsepa.pop grease separator.

A company of the GRAF group

Since 2014 KLARO has been part of the GRAF group. The GRAF brand has been synonymous with high quality plastic products in the field of water resource management for over 50 years. GRAF is well-known to KLARO as a long-standing customer and supplier of septic tanks. The high-quality separator containers are manufactured in the GRAF facilities. Therefore you benefit from the expertise and quality of two established brands when you buy a KLARO product.





GRAF company in Teningen

Grease separator system

A grease separator operates according to the principle of phase separation. It consists of a separation zone, a fat collector, a sludge trap and a sampling point. The system reduces the flow rate of the wastewater so that solids, such as food wastes, sink and settle in the sludge trap. The contaminants with lower density than water, i.e. greases and oils float on the water surface. The purified water free of grease is drained.

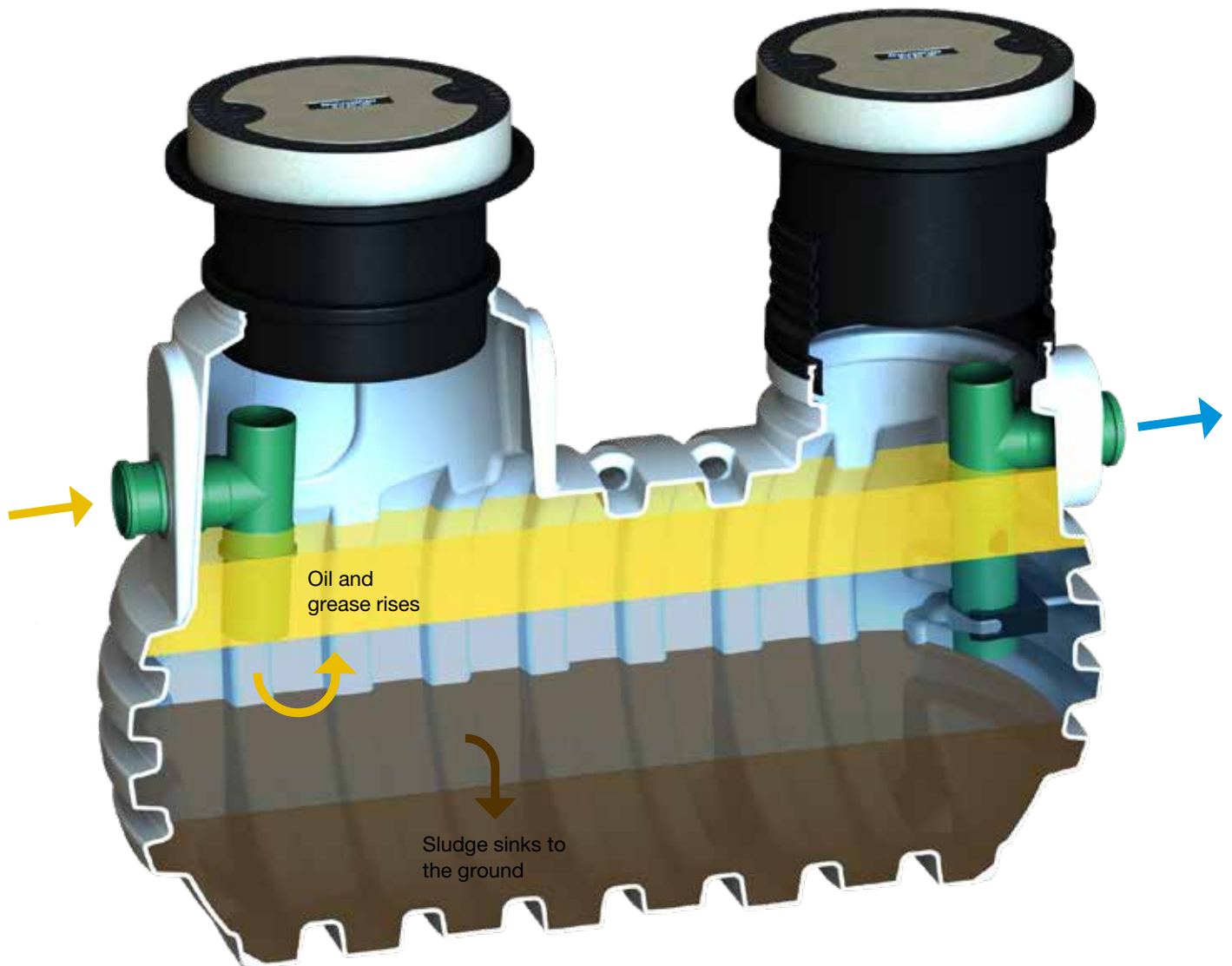
The choice of the nominal size of the separator is stipulated in part 2 of EN 1825. Furthermore, the provisions from the wastewater regulations of the respectively relevant authority must be observed.



 Grease storage area

 Separation area

 Sludge storage

Areas of application



Commercial kitchen

A grease separator must be installed where water is contaminated with greases to an extent that exceeds the normal household wastewater contamination. Operators of the following facilities must ensure that a suitable, functioning separator is installed.

Separation systems are classified according to the NS (nominal size). As soon as you make an inquiry for a separator with us, we will calculate your required NS. Factors such as the water temperature and the use of cleaning agents must be included in the calculations.

- Kitchen enterprises and commercial kitchens (restaurants, hotels, canteens, ...)
- Grills, frying and deep-fry kitchens
- Food distribution points (with return dishes)
- Butcher shops / meat and sausage processing plants
- Slaughterhouses (large abattoirs)
- Oil mills / refineries for cooking oil / margarine production facility
- Canning factories/ ready meals processing plant



KLsepa.pop NS 1-4 Saphir



Downstream sampling shaft
(see page 9)

KLsepa.pop

		Volume			Container geometry		Weight
NS	DN	Grease	Sludge	Total	Diameter	Height <small>(Without cover)</small>	approx.
[l/s]	[mm]	[l]	[l]	[l]	[m]	[m]	[kg]
1 - 200	110	200	200	500	1.13	1.04	41
2 - 200 - 2	110	200	200	500	1.13	1.04	41
2 - 200 - 3	110	300	200	730	1.16	1.34	70
2 - 400	110	200	400	730	1.16	1.34	70
2 - 500	110	300	500	1025	1.16	1.67	100
4 - 500	110	300	500	1025	1.16	1.67	100

Effectiveness tested according to EN 1825 of the TÜV Rheinland.

Description of system

KLsepa.pop NS 4-15 *Diamant*

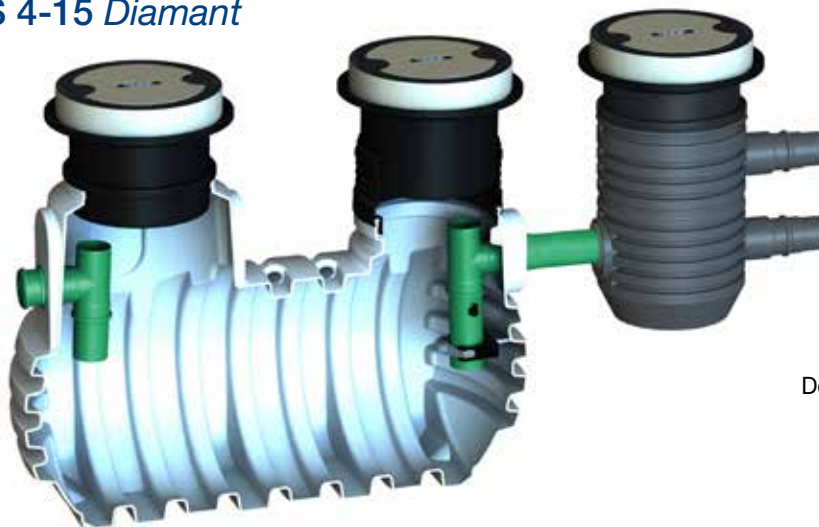

Downstream sampling shaft
(see page 9)

		Volume			Container geometry			Weight
NS	DN	Grease	Sludge	Total	Length	Width	Height (Without cover)	approx.
[l/s]	[mm]	[l]	[l]	[l]	[m]	[m]	[m]	[kg]
4 - 700	160	350	700	2070	2.45	1.15	1.66	165
7 - 700	160	350	700	2070	2.45	1.15	1.66	165
10 - 1500	200	600	1500	3160	2.45	1.40	1.90	250
15 - 1500	200	600	1500	3160	2.45	1.40	1.90	250

Effectiveness tested according to EN 1825 of the TÜV Rheinland.

External sampling shaft

In some countries downstream sampling is stipulated according to the current standard. Therefore, the sampling shaft is part of the separator system. It is used, in addition to the prescribed collection of wastewater samples, for the control, maintenance and cleaning of the system.

Internal sampling point

The KLsepa.pop separator system also provides the option of integrated sampling. A sampling port is installed at the discharge so that it is accessible from the riser shaft.

External sampling	Dimensions			Weight (Without cover)
	Length	Width	Height	approx.

DN 110 to 200 connection 101 cm 69 cm 100 cm 19 kg

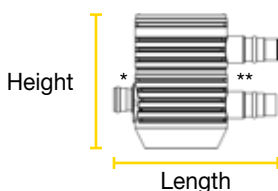

Attention:

In many countries and regions an external sampling point is stipulated.



Dome assembly

- Including standard lip seals for easy connection
- Sealed to ground level
- Easily adapted to ground level with telescopic/tilting dome shaft
- Excellent stability due to modern technology
- Unique precision fit of the components through new production process
- Suitable for car/truck traffic with standard concrete rings and covers
- Fully adjustable ground level cover over the tank top, 5° tiltable (ideal for asphalt surfaces)

Cover	Dimensions		Weight
	Dia-meter	Height	approx.
Concrete passable for cars	74 cm	57 - 75 cm	120 kg
Concrete passable for trucks	78 cm	61 - 79 cm	170 kg

Attention:

To guarantee lasting practicability for vehicles / trucks, a sub-structure from concrete around the domes is necessary.

Further information is available in the installation instructions.

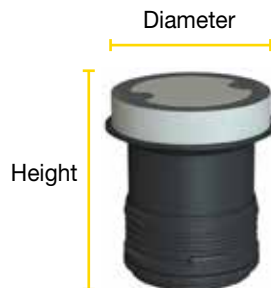

Adjustable in height and tiltable

The dome assemblies are fully adjustable for height and tilt (up to 5 %) providing a high degree of flexibility in installation.

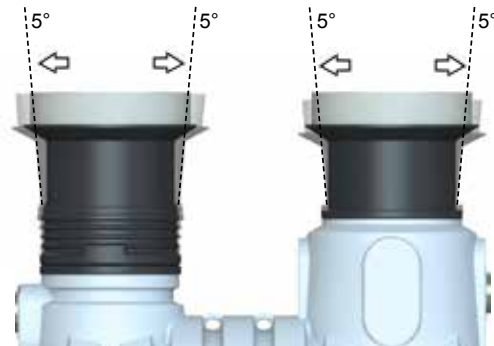

Warning systems

According to EN 1825, grease separators can be equipped with an automatic warning system.

Available Sets:

Typ 1: Fat-layer-thickness alarm

Typ 2: Fat-layer-thickness and backwater detection



Warning system type 1

Mode of operation

Using sensors that are mounted in the separator, the following functions can be monitored:

- Monitoring of the layer thickness, i.e. alert if a defined threshold for the maximum collection capacity of grease has been reached.
- Detection of backwater, i.e. if the general fluid level rises, e.g. due to a clogged float.

Check list - road map for separator

1. Replacement or new installation?

The operator must first determine whether the separator is a completely new installation or whether it is a replacement of an older existing separator system. This makes a difference in so far as a new installation in general must be approved by the relevant authority (water authority, environmental agency, town council etc.). If it is a replacement, the operator only needs to report the planned new separator.

2. Assessment

Next, an assessment is made by KLARO to find the optimum system to meet the needs of the operator. An assessment is also required for a replacement system as well as a new installation, as the external conditions, such as operating hours, water connections and/or the wastewater present, can change over the years.

The following steps may differ according to the region/country:

3. Specification

After KLARO carried out the assessment, it must be submitted to the relevant authority by the operating company or the construction company commissioned by the operating company.

4. Installation

Once the building application has been approved, construction work can begin. The commissioned construction company must be certified in compliance with the Water Resources Act (WHG) 19 L 57/58.

5. General inspection

After completion of the installation of the separator system, a general inspection according to DIN 4040-100 must be carried out. A specialist in separator technology should check the installation, the sealing of the container and the operation of the system. This should be repeated in regular intervals of 5 years.

6. Commissioning

After successful completion of the general inspection the system can be commissioned after being filled with water. However, it must be ensured that the tank was cleaned after installation, i.e. whether potential contamination was removed.

Monitoring and drainage

The basics

The operator, or a person appointed by him, must perform a monthly self-inspection of the facility. The person carrying out the inspection must be a qualified specialist or be trained by one.

Monthly self-monitoring

Monthly internal self-inspection procedure:

- Check the technical equipment for abnormalities
- Visual check of the inlet and outlet area of the sludge trap and grease separator
- Sign in the log book

Recommendation: Carry out check during each drainage.

Operating manual

Measures taken with regard to self-inspection, maintenance, potential defects and disposal of extracted contents (keep disposal records) must be documented in a log book. If the system is to be used for greasy wastewater which also contains washing up liquid or cleaning products, these products must be suitable for use with a separator system and must not form any stable emulsions.

Drainage and disposal

Only certified disposal companies may drain the content of the separator system and dispose of it.

To drain the tank, please proceed as follows:

- At first, the layer of grease which has collected on the surface must first be extracted. This prevents grease from entering the outlet as the water level falls during emptying and being washed out of the separator once operation is restarted. Only once the layer of grease has been completely removed may the water underneath be pumped out.
- Then the inlet lines and separator tank must be rinsed out with sufficient warm water (approx. 30°C). The water used for cleaning must then be pumped out completely.
- The entire system, sludge trap and grease separator must then be filled with fresh water in order to restore functionality to resume operation.
- Check the odour-proof cover and check the condition of the seal and sealing effectiveness and clean, if necessary.

The separator system must be completely drained, cleaned and filled up with clean water at regular intervals, if possible, every two weeks, but at least once a month. However, it is recommended to initially check the condition more frequently, until some individual experience with regard to the operation is gathered by the operator. With the help of this gained experience the final control intervals can be determined, as the separated grease can turn into aliphatic acid caused by bacteria within a few days, which can lead to strong unpleasant odour.

5-yearly general inspection

Every five years, the separator must be given a general inspection, as with commissioning, by a person qualified in separator technology.



CE declaration of performance ...

... according to REGULATION (EU) no. 305/2011

Construction product	Separator system for greases, consisting of a separator and a sludge trap																																																																														
Product type	KLsepa.pop																																																																														
Primary technical specifications	<table border="1"> <thead> <tr> <th>Type designation</th> <th>NS [l/s]</th> <th>Sludge trap [l]</th> <th>Grease storage [l]</th> <th>Diameter [mm]</th> <th>Length [mm]</th> </tr> </thead> <tbody> <tr><td>KLsepa.pop 1-200-2</td><td>1</td><td>200</td><td>200</td><td>1130</td><td>-</td></tr> <tr><td>KLsepa.pop 1-200-3</td><td>1</td><td>200</td><td>300</td><td>1160</td><td>-</td></tr> <tr><td>KLsepa.pop 1-400</td><td>1</td><td>400</td><td>200</td><td>1160</td><td>-</td></tr> <tr><td>KLsepa.pop 2-200-2</td><td>2</td><td>200</td><td>200</td><td>1130</td><td>-</td></tr> <tr><td>KLsepa.pop 2-200-3</td><td>2</td><td>200</td><td>300</td><td>1160</td><td>-</td></tr> <tr><td>KLsepa.pop 2-400</td><td>2</td><td>400</td><td>200</td><td>1160</td><td>-</td></tr> <tr><td>KLsepa.pop 2-500</td><td>2</td><td>500</td><td>300</td><td>1160</td><td>-</td></tr> <tr><td>KLsepa.pop 4-500</td><td>4</td><td>500</td><td>300</td><td>1160</td><td>-</td></tr> <tr><td>KLsepa.pop 4-700</td><td>4</td><td>700</td><td>350</td><td>2450</td><td>1150</td></tr> <tr><td>KLsepa.pop 7-700</td><td>7</td><td>700</td><td>350</td><td>2450</td><td>1150</td></tr> <tr><td>KLsepa.pop 10-1500</td><td>10</td><td>1500</td><td>600</td><td>2450</td><td>1400</td></tr> <tr><td>KLsepa.pop 15-1500</td><td>15</td><td>1500</td><td>600</td><td>2450</td><td>1400</td></tr> </tbody> </table>	Type designation	NS [l/s]	Sludge trap [l]	Grease storage [l]	Diameter [mm]	Length [mm]	KLsepa.pop 1-200-2	1	200	200	1130	-	KLsepa.pop 1-200-3	1	200	300	1160	-	KLsepa.pop 1-400	1	400	200	1160	-	KLsepa.pop 2-200-2	2	200	200	1130	-	KLsepa.pop 2-200-3	2	200	300	1160	-	KLsepa.pop 2-400	2	400	200	1160	-	KLsepa.pop 2-500	2	500	300	1160	-	KLsepa.pop 4-500	4	500	300	1160	-	KLsepa.pop 4-700	4	700	350	2450	1150	KLsepa.pop 7-700	7	700	350	2450	1150	KLsepa.pop 10-1500	10	1500	600	2450	1400	KLsepa.pop 15-1500	15	1500	600	2450	1400
Type designation	NS [l/s]	Sludge trap [l]	Grease storage [l]	Diameter [mm]	Length [mm]																																																																										
KLsepa.pop 1-200-2	1	200	200	1130	-																																																																										
KLsepa.pop 1-200-3	1	200	300	1160	-																																																																										
KLsepa.pop 1-400	1	400	200	1160	-																																																																										
KLsepa.pop 2-200-2	2	200	200	1130	-																																																																										
KLsepa.pop 2-200-3	2	200	300	1160	-																																																																										
KLsepa.pop 2-400	2	400	200	1160	-																																																																										
KLsepa.pop 2-500	2	500	300	1160	-																																																																										
KLsepa.pop 4-500	4	500	300	1160	-																																																																										
KLsepa.pop 4-700	4	700	350	2450	1150																																																																										
KLsepa.pop 7-700	7	700	350	2450	1150																																																																										
KLsepa.pop 10-1500	10	1500	600	2450	1400																																																																										
KLsepa.pop 15-1500	15	1500	600	2450	1400																																																																										
Intended use	Separation and containment of animal fats from the wastewater																																																																														
Manufacturer	KLARO GmbH Spitzwegstrasse 63 D-95447 Bayreuth																																																																														

Harmonised technical specification	Key features	Performance	Assessment and review of the constancy of performance
EN 1825-1:2004	Fire behaviour	E	System 3*
	Liquid tightness	passed	System 4
	Effectiveness	passed	
	Load carrying capacity	passed	
	Durability	passed	

*Test facility: Institute for Testing (Prüfinstitut) Hoch, Lerchenweg 19, 97650 Fladungen
We confirm that the named construction product type KLsepa.pop complies with the declared performances.

Address



KLARO GmbH
Spitzwegstraße 63
95447 Bayreuth

Telephone



+49 (0) 921 16279-0
Technical hotline:
+49 (0) 921 16279-330

Website



Further information can
be found under:
www.klaro.eu

Message



Email:
info@klaro.eu

